

Sensor for ejection control at forging presses. The formed pressed parts are detected in non-contacting manner so that the machine control interrupts the working cycle in case of material stoppage. The response sensibility regarding the warm material depends on temperature, size and distance of the object.

The short-circuit-proof all-current design with two-wire connection is also suitable for relay and SPS controls due to its low residual current.

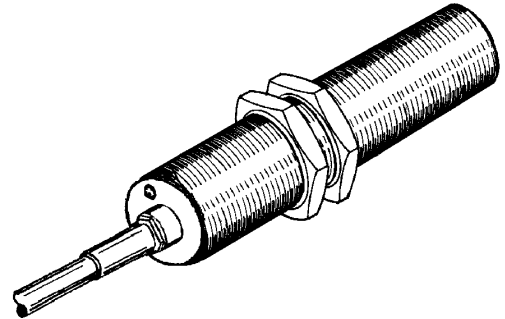

Technical Data

Type	OKL 203.05 G
Art.-No.	7802A
Response temperature	350 °C / 623 K
View angle	2°
Distance ratio	29:1
Detected surface at 2m	∅ 70 mm
Output	normally open
Supply voltage	20 - 260 V AC/DC
Power frequency	40 - 440 Hz
Ripple voltage	max. 15 % (DC)
Load current max.	5 - 400 mA
Short-time load current	2 A / 10 ms 0,8 A / 100 ms
Short circuit protection	yes, pulsing
Residual current	1,7 mA / 260 V AC 1,0 mA / 24 V DC
Voltage drop	9 V
Operating frequency	1500 Hz (DC)
Ambient temperature	-25 ... +60 °C
Protection class	IP 67
Connection	2 m PUR-cable
Function display	LED
Housing	Brass, nickel plated
Accessories (not included in the scope of supply)	Art.-No.
Tube with air connection OL 25 L	9828G

Diagram of Connections

